

---

— USER'S GUIDE —

---



**LASER ATLANTA**

Laser Atlanta Optics, Inc. is headquartered in Norcross, GA. In addition to the SpeedLaser product line, Laser Atlanta develops and manufactures laser-based optical measurement and detection devices for commercial and industrial use.

The SpeedLaser, Advantage, ProFiler and MiNiLaser products are supported by an international network of Laser Atlanta dealers. Call for the location of the dealer closest to you.

In Canada:



Phone: (800) 331-5815 (613) 253-7000  
Fax: (613) 253-0023  
Web: [www.davtech.ca](http://www.davtech.ca)  
Email: [sales@davtech.ca](mailto:sales@davtech.ca)

© Copyright 1996-2002 Laser Atlanta Optics, Inc.  
Reproduction, adaptation, or translation of this manual is prohibited without prior written consent of Laser Atlanta Optics, Inc., except as allowed under copyright laws.

**Software Version 1.00 and above**

© Copyright 1995-2002 Laser Atlanta Optics, Inc.  
The programs that control this product are copyrighted and all rights are reserved. Reproduction, adaptation, or translation of those programs without prior written consent of Laser Atlanta Optics, Inc. is prohibited.



## **USER'S GUIDE**

---

**Laser Atlanta Optics, Inc.**

2827 Peterson Place  
Norcross, GA 30071

Phone (770) 446-3866  
FAX (770) 840-0462

[http:// www.LaserAtlanta.com](http://www.LaserAtlanta.com)  
Email: [Laser@LaserAtlanta.com](mailto:Laser@LaserAtlanta.com)



# TABLE OF CONTENTS

<b>1</b>	<b>USER'S GUIDE .....</b>	<b>2</b>
	Appendices.....	5
<b>2</b>	<b>PACKING LIST .....</b>	<b>10</b>
<b>3</b>	<b>TO POWER ON.....</b>	<b>15</b>
<b>4</b>	<b>TO POWER OFF .....</b>	<b>15</b>
<b>5</b>	<b>SPEED MEASUREMENT .....</b>	<b>16</b>
	Measuring Speed.....	16
	Approaching and Receding Targets .....	16
	Approaching and Receding Targets .....	17
<b>6</b>	<b>RANGE MEASUREMENT .....</b>	<b>18</b>
<b>7</b>	<b>RANGE MEASUREMENT .....</b>	<b>19</b>
<b>8</b>	<b>THE MENU SYSTEM .....</b>	<b>20</b>
<b>9</b>	<b>DISPLAY MENU .....</b>	<b>25</b>
<b>10</b>	<b>CLEANING THE SPEEDLASER'S OPTICS .....</b>	<b>30</b>

# APPENDICES

<b>A</b>	<b>Troubleshooting/ Error Messages</b>	<b>33</b>
<b>B</b>	<b>Care and Maintenance</b>	<b>34</b>
<b>C</b>	<b>Technical Specifications</b>	<b>36</b>
<b>D</b>	<b>SpeedLaser and Accessory Diagrams</b>	<b>37</b>
<b>E</b>	<b>Measuring Surface Datum</b>	<b>39</b>
<b>F</b>	<b>Battery Handles Notes</b>	<b>40</b>

**Warranty**

**Rear Cover**

## CHAPTER 1 Introduction

Thank you for purchasing the SpeedLaser from Laser Atlanta. This rugged laser speed gun integrates the latest in solid-state laser technologies to bring you hand-held, eye-safe laser speed and distance measurement.

The SpeedLaser is a Class 1 eyesafe, multi-function device generally used to measure range and speed of targets up to 9144 meters away.

The laser technology utilized by the SpeedLaser is called LIDAR: **L**ight **D**etection **A**nd **R**anging. Your SpeedLaser uses a pulsed time-of-flight method to accurately calculate distances based on over two hundred pulses of light per second. Sophisticated computer algorithms reduce these individual distance measurements to extremely accurate speed and range measurements.

To get the most from your new SpeedLaser, please take the time to read through this manual. For your convenience and ease of understanding, it has been divided into 4 sections:

Chapter 1	Introduction
Chapter 2	Getting Started
Chapter 3	User Setting's
Appendices	Information on care, troubleshooting, and specifications

If you have questions or comments, please do not hesitate to contact Laser Atlanta via any of the following means:

voice: (770) 446-3866

fax: (770) 840-0462

Email: [sales@laseratlanta.com](mailto:sales@laseratlanta.com)

Web: <http://www.laseratlanta.com>

## Cautions

Every step has been taken to ensure your SpeedLaser is completely safe to use. However, certain common sense precautions should always be taken when using your SpeedLaser.

- Do not open the case under any circumstances.
- Do not point the SpeedLaser directly at the sun.
- Use only Laser Atlanta approved power sources.
- Do not leave SpeedLaser in areas of high humidity.
- Do not place SpeedLaser on unstable surfaces.
- Always transport the SpeedLaser in its carrying case.

Your SpeedLaser is a Class 1 Laser Product that complies with 21 CFR 1040.10 and 1040.11. Class 1 is the lowest classification of laser product with regards to risk in use. This class of laser cannot emit levels of optical radiation above the exposure limits for the eye, under any exposure conditions inherent to the laser product.

**Caution: The use of optical instruments with this product will increase eye hazard. Do not point this laser at anyone with optical viewing devices within 15 meters of the operator.**

Although optical viewing instruments may increase eye hazard, it is unlikely that actual damage can occur. Prescription eyeglasses, contact lenses, and sunglasses are not considered optical gain devices since they merely correct the focus of the human eye to normal.

Optical devices that provide magnification may increase the risk of eye-hazard. These include binoculars, telescopes and magnifying glasses.



## **Capabilities**

### *Performance*

- Target Acquisition in 0.3 seconds
- Speed Accuracy of  $\pm 1$  kph
- Range to 9144 meters

### *Advanced Input-Output*

- Remote Fire capability
- Data Collection via RS-232 port
- Data Collection via PCMCIA SRAM Cards

### *Ease of Use*

- Menu Driven
- Head Up Display (HUD) shows both target and/or data through the same sighting mechanism
- Rechargeable NiMh Battery Handle
- 12 V Cigarette Adapter
- Optional 8X Monoscope for distant viewing
- Optional Shoulder Stock for steadying while hand-held
- Optional Monopole and Tripod for mounting

### *Environmental Features*

- Water Resistant
- Ruggedized Case
- Rechargeable NiMh Battery Handles



# PACKING LIST

---

Please check to make sure the following items were included in your shipment:

- SpeedLaser LIDAR Gun
- Carrying Case
- 110 volt Battery Charger
- 2 Battery Handles
- 12 volt Vehicle Power Cable
- 12 volt Vehicle Power Cable
- User's Guide
- Warranty Card

Additionally, you may have received the following optional parts:

- RS-232 Serial Data Cable
- 8X Monoscope Kit
- Shoulder Stock Kit

Please see Appendix D for diagrams of these items.

## SpeedLaser Controls & Layout

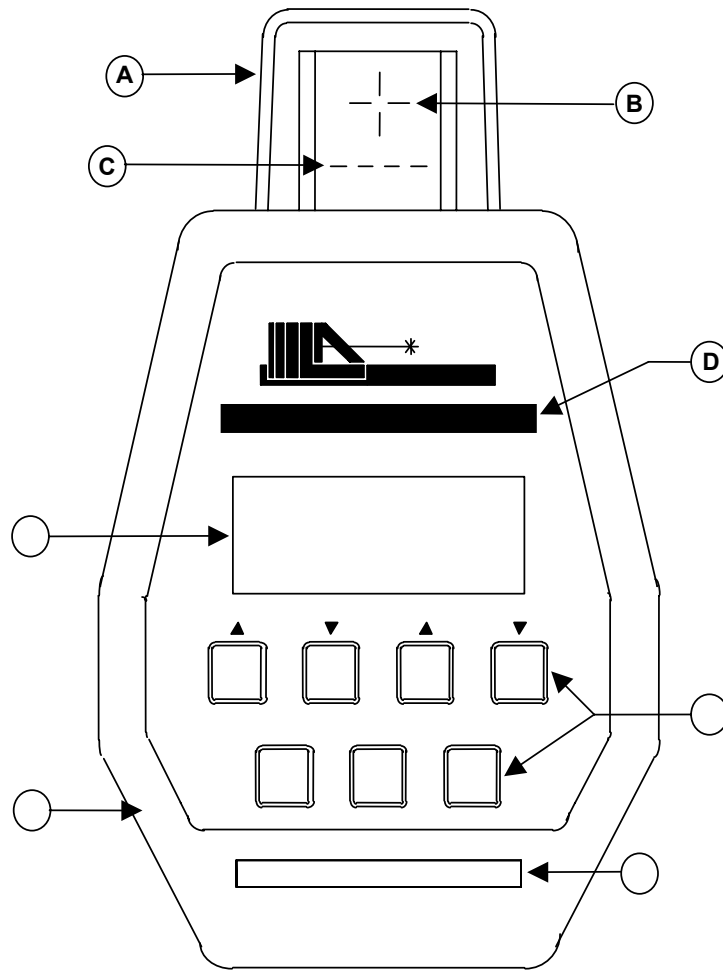

- |                          |                           |
|--------------------------|---------------------------|
| A. HEAD UP DISPLAY (HUD) | E. LIQUID CRYSTAL DISPLAY |
| B. HUD SIGHTING RETICLE  | F. KEYPAD KEYS            |
| C. HUD CHARACTER DISPLAY | G. REAR BUMPER            |
| D. SERIAL NUMBER         | H. PCMCIA CARD SLOT       |

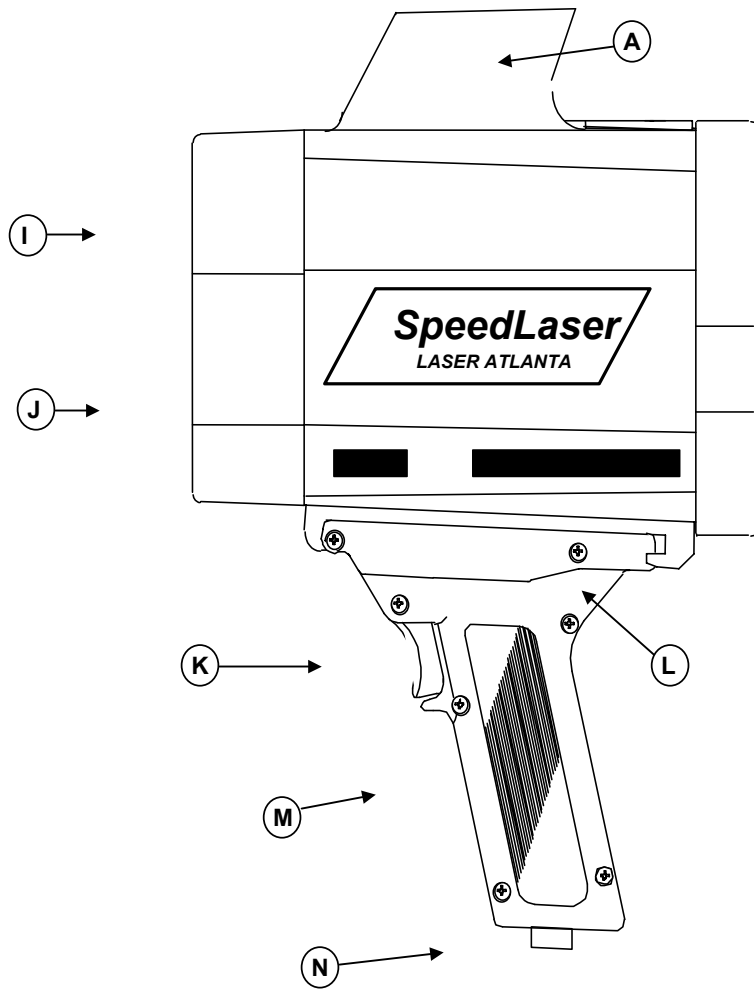

- |                    |                       |
|--------------------|-----------------------|
| I. TRANSMIT OPTICS | M. BATTERY HANDLE     |
| J. RECEIVE OPTICS  | N. EXTERNAL DATA PORT |
| K. HANDLE TRIGGER  |                       |
| L. HANDLE LATCH    |                       |

## Battery Handle Power

The SpeedLaser comes equipped with two (2) rechargeable battery handles. They have been shipped completely uncharged, so you will need to charge them with the wall charger or 12V cigarette cable completely before first use. Each handle will provide an average of five (5) hours of continuous use per charge.

These handles are also capable of powering the SpeedLaser from a 12V source such as an automotive cigarette power adapter using the cable provided. Plug the small circular connector onto the bottom of the handle and the cigarette adapter end into an automotive cigarette-power adapter. You can charge the handles in this manner as well as operate the unit.

### To charge your battery handle:

1. Plug the circular connector into the side of the handle. Do not force the connector as it is keyed...slowly rotate the connector and push gently until it clicks and locks into place.
2. Plug the charger into a standard 120 VAC power receptacle OR plug the cigarette adapter into a power source.
3. Charge the handle for ten to twelve hours.
4. To remove the connector, pull gently downward on the outside of the connector.
5. Unplug the charger from the wall. The handle is now charged.

### CAUTION: DO NOT

- Charge handles with other chargers/power supplies
- Short circuit the battery pins
- Charge handle for over sixteen (16) hours continuously

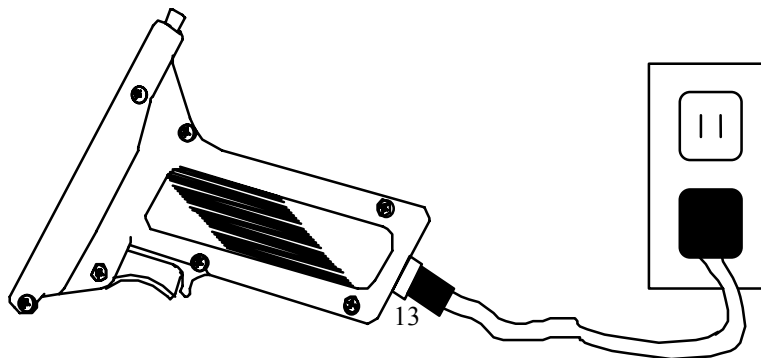

## Connecting a Handle

### To install a handle onto the SpeedLaser:

1. Press the handle latch forward on the handle.
2. Push the front of the handle into the front handle catch on the bottom of the SpeedLaser.
3. Rotate the rear of the handle upward.
4. Release the handle latch.

NOTE: Make certain the handle latch slides into position and secures the handle to the SpeedLaser. If necessary, push the handle latch rearward to secure the handle to the SpeedLaser.

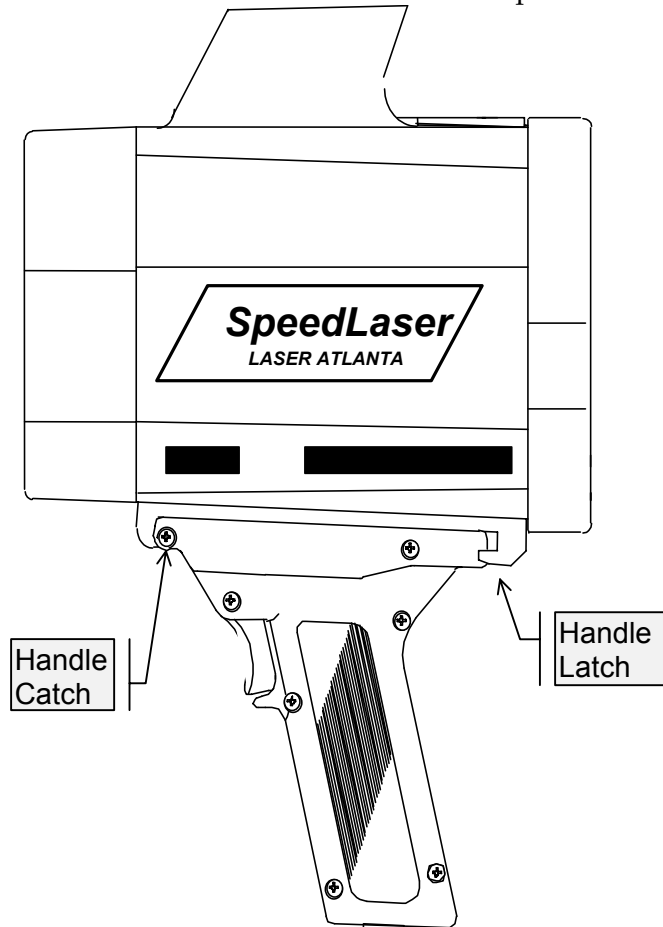

## Turning the SpeedLaser ON and OFF

# To POWER ON

---

- 1) Press the PWR key on the back of the SpeedLaser and hold for one second.

Note: The self-test (pg. 19) will automatically run when the unit is first powered ON.

# To POWER OFF

---

- 1) Press the PWR key on the back of the SpeedLaser and hold for three seconds.

**Note:** Keep the key pressed until no information is displayed on the LCD. If the button is not depressed for a long enough time, it toggles the LCD backlight ON and OFF.

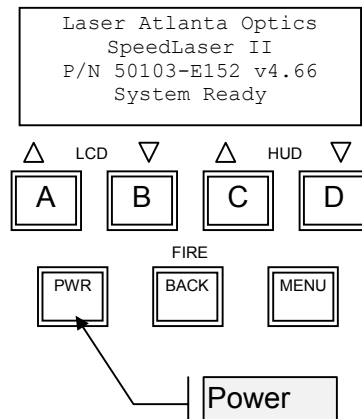



## SPEED MEASUREMENT

When the SpeedLaser is first turned ON, it automatically runs the self-test function. To capture a speed, simply follow the procedure below.

### MEASURING SPEED

**\*Always verify operational procedures for Alignment Check\***

1. Align the HUD Sighting Reticule on the target you wish to measure the speed of.
2. Squeeze and hold the Handle Trigger.
3. Release the Handle Trigger to stop measurement and lock information in the HUD and on the LCD.

The speed will be shown in two places...on the rear bottom right of the LCD and in the HUD (if selected) character display. Notice that the speed displayed is always rounded to the nearest kph.

The distance to the target will be shown on the left side of the LCD.

**NOTE:** Pressing the trigger will take you to the *Speed Display Page* regardless of any other mode the SpeedLaser may be in. (The exception is in TEST mode.)

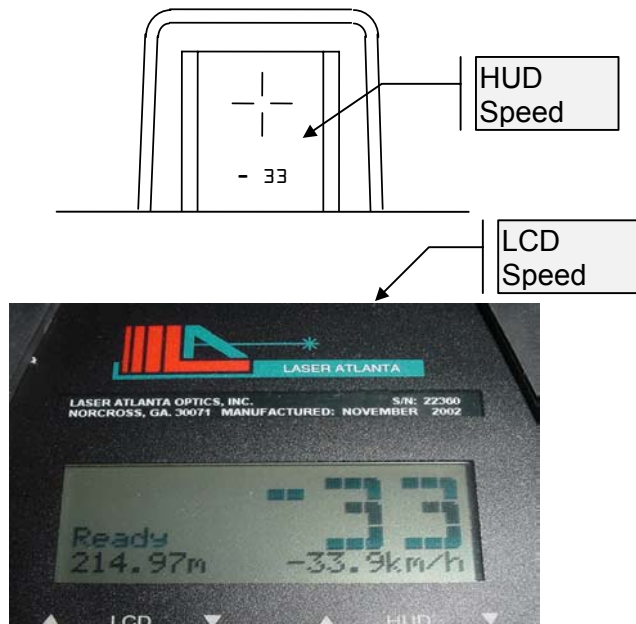

# APPROACHING AND RECEDING TARGETS

The SpeedLaser can measure the speeds of both approaching (oncoming) and receding targets.

The speed displayed in the HUD and on the LCD will be preceded by a '-' when the target is receding.

## Example of an Approaching

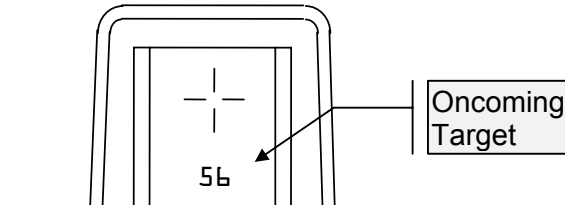

## Example of a Receding

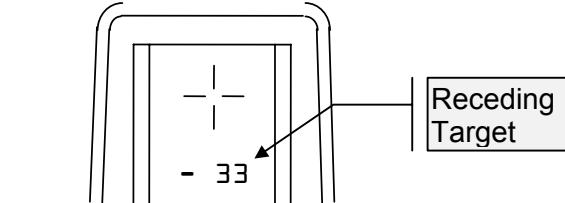

## Daily Self-Test and Alignment Check Procedure

This test checks the memory and timing circuits and allows the operator to verify that the HUD crosshairs are aligned with the laser. The alignment crosshairs in the HUD are set at the factory and should not need realignment over the life of the SpeedLaser.

- 1) Press MENU A to place the unit in Test & Reset Mode.
- 2) Note if all of the tests pass (OK will be displayed.)
- 3) Note if all of the segments in the HUD are turned on. (This will appear as a four-segment crosshair and four 8's.)
- 4) Range Test – Stand at a known position, aim at a target at a known distance, squeeze trigger until tone sounds. Confirm known range in LCD panel. Repeat for one other known distance.
- 5) Horizontal Alignment Test - Locate a tall, vertical object (such as a utility pole) with clear sky behind it (and preferably > 45 meters away.)
- 6) Aim to the right of the object, and pull the trigger.
- 7) While keeping the trigger pulled, slowly sweep the crosshair sight to the left. Press (D) Done when completed.
- 8) The distance should be displayed in the HUD **only** when the target edge is in view of the crosshair.
- 9) Vertical Alignment Test – Turn the unit 90 degrees sideways. Repeat steps 5 – 8. Press MENU to exit Test Mode.

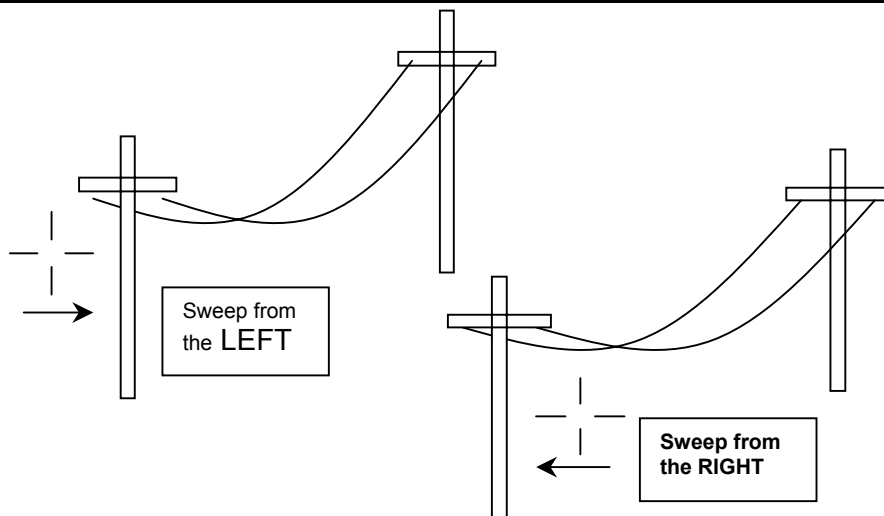

# RANGE MEASUREMENT

---

## To make a range measurement:

1. Press Power.
2. Align the HUD Sighting Reticule on the target that you wish to measure the range to.
3. Squeeze and hold the Handle Trigger.
4. Release the Handle Trigger to stop measurement and lock the measurement data temporarily in the HUD and on the LCD.

Notice that the distance displayed in the HUD is always rounded to the nearest meter.

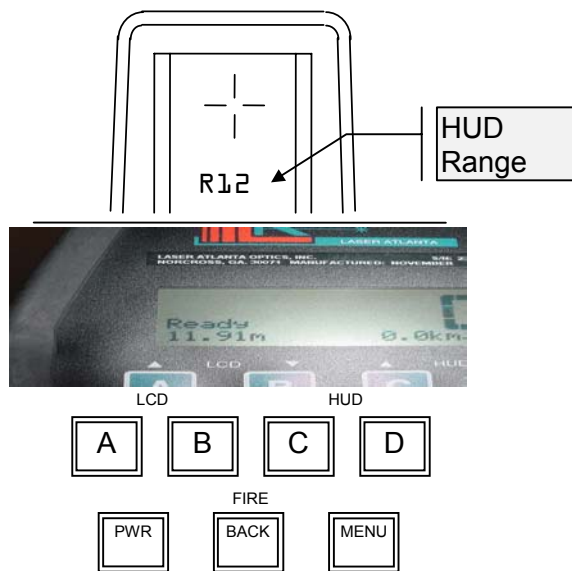

## Chapter 3

### User Settings

The SpeedLaser provides a number of user settable features to help the user in making speed and distance measurements. These are accessible from the sub-menus.

## THE MENU SYSTEM

---

The menu system is reached by depressing the MENU key from the SPEED page.

- The top left of the LCD displays the Menu Name.
- The top right of the LCD displays the Menu Page. This reflects which keys have been pressed since the top menu page (Pg 0).
- Other lines list choices selectable by the A, B, C, and D keys.

The menu system is negotiated via the following keys:

A	Select choice A
B	Select choice B
C	Select choice C
D	Select choice D
BACK	Go back to the previous menu page
MENU	Exit the Menu and return to SPEED page

When the '@' symbol appears next to a menu selection instead of a colon ':', that choice is currently selected.

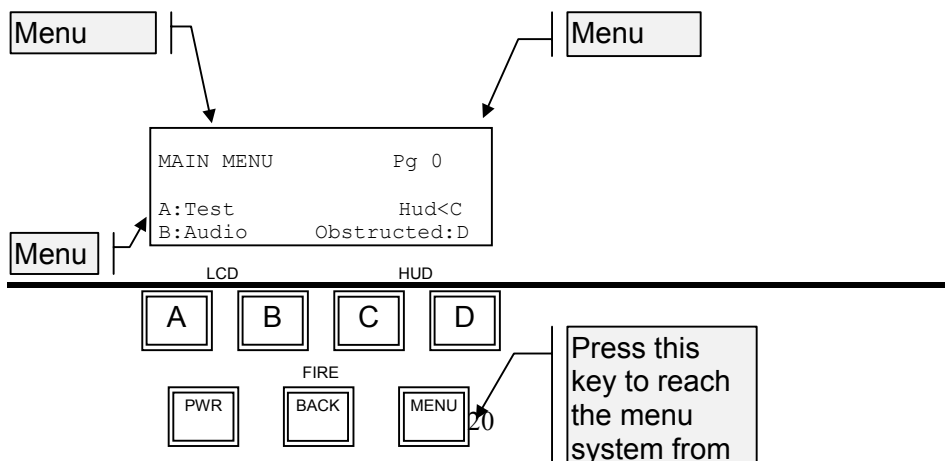

Please note that it is ***not possible*** to permanently save user settings. Each time the SpeedLaser power is cycled, the menus will be reset to their factory defaulted values.

The remainder of this Chapter presents a diagram and description of each sub-menu. For convenience, the complete menu tree is diagrammed on pages 18 and 19.

To quickly access any desired menu, press the MENU key and then the sequence of letter shown at the top right of the display diagram on any page.

For example, to access the Audio Quality Chirp menu, you would press the following keys in sequence:

MENU  
B  
C

## Main Menu

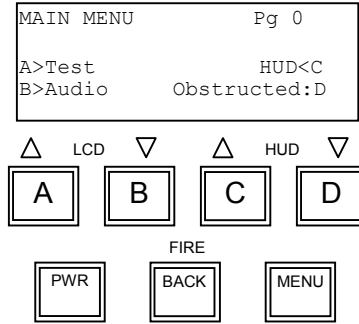

#	Action	Key
1	Turn On	PWR
2	Select MENU	MENU

The Main Menu is the starting menu page for all user configurable functions. These functions are divided into four groups:

- Self-Test
- Audio
- HUD
- Obstructed

See the Menu Tree and the description pages that follow for instructions on using these settings.

**Reminder:** The user settings are not permanent. The gun will revert to standard factory settings when the power is cycled.

## Test Mode

### Performing the Self-Test

#### MENU A

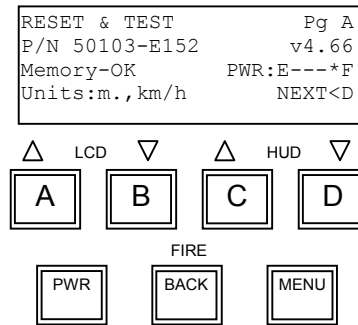

#	Action	Key
1	Turn On	PWR
2	Select MENU	MENU
3	Select TEST MODE	A

**Note:** The self-test diagnostic functions are performed automatically upon powering the gun on.

The self-test performs the following functions:

- The software version is displayed in the LCD.
- The memory functions are checked.
- The battery voltage is displayed. Common values are 6 to 7 VDC.
- The speed and distance units of measure are displayed on the LCD. (Note: These units are pre-configured at the factory and cannot be set by the end-user.)
- All LED segments in the HUD are cycled through the numerals 1 to 9 and then finally displayed as 8888.
- Range (distance measurement) mode is automatically turned on for this page. This allows the operator to perform an alignment check (see procedure on following pages.)

If any of the diagnostic functions fail, a failure warning will be displayed on both the LCD and in the HUD. A warning tone will sound and the SpeedLaser will prohibit firing of the laser. The operator should attempt to power the unit down and back on and run the self-test again.



## Audio

toggling the beeper tone ON and OFF  
MENU DA

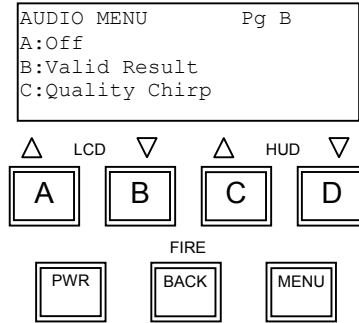

#	Action	Key
1	Turn On	PWR
2	Select MENU	MENU
3	Select SETUP MENU	B
3	Select AUDIO	A

If selection A: Off is NOT selected, the unit will emit a short beep each time a menu key is pressed.

If selection B: *Valid Result* or C: *Quality Chirp* are selected, the audio beeper will sound for the following conditions:

**Valid Result** The beeper will emit a tone when a valid speed or distance measurement is made.

**Quality Chirp** When the SpeedLaser is making a speed or distance measurement (in Range Average or Real-time Range modes only), a tone representative of the quality of the received laser signal is sounded. When strong laser returns are acquired, the tone will be solid. Weaker returns will give a weaker, broken tone.

**Note:** The following conditions will signal an alarm regardless of the settings on this menu page.

**Voltage Low** A solid tone will sound when the voltage is low.

**Fail** Any failure mode will sound a solid tone.

# DISPLAY MENU

---

Setting the LCD and HUD intensities  
MENU

- Pressing A will toggle the backlight On and OFF.
- Instantaneously pressing the PWR key toggles the backlight ON and OFF.
- The A key adjusts the LCD Contrast HIGHER.
- The B key adjusts the LCD Contrast LOWER.
- The C key adjusts the HUD intensity HIGHER.
- The D key adjusts the HUD intensity LOWER.

## **LCD Backlight**

Turning On the LCD Backlight

---

Note: Briefly pressing the PWR button will also toggle the backlight ON and OFF.

---

## **LCD Contrast**

Adjusting the LCD Contrast

Press the A or B key from the Speed Display Page to adjust the contrast up and down.

## HUD Mode

Setting the HUD LED Intensity  
MENU C

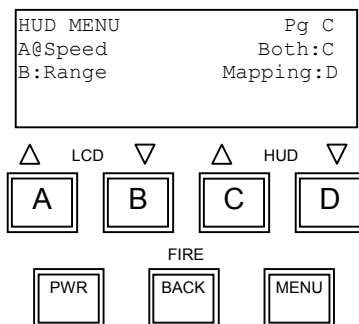

#	Action	Key
1	Turn On	PWR
2	Select MENU	MENU
3	Select HUD MENU	D

This setting chooses what is displayed in the HUD; *Speed*, *Range*, or *both Speed and Range*.

*Speed*     Select A to exclusively display Speeds in the HUD.

*Range*     Select B to exclusively display distances in the HUD.

### Both Speed and Range

Select C to alternately display Speed and Distance in the HUD. The values will rotate between the current speed and the current range.

# WHAT THE DAILY TEST ACCOMPLISHES

To ensure that the SpeedLaser is in good working order, the SpeedLaser should be tested daily using the test procedures described in the SpeedLaser manual. These tests verify and reset proper operation of the hardware and firmware as described below:

## **BUILT IN TEST:**

When the operator presses Menu>Test the SpeedLaser runs a Built-In – Test program. The Built-In-Test program will verify that the SpeedLaser firmware is loaded correctly and that it executes its data gathering, sorting, filtering, conversion and linear regression algorithms correctly.

## **DISPLAY TEST:**

Allows the operator to verify that the seven segment display used to show speed of the target vehicle is in good working order by displaying a simple known pattern. The operator can then confirm that each segment operates correctly.

## **TIMER or RANGE TESTS:**

The SpeedLaser hardware ONLY measures Time. Range and Speed are computed values derived from multiple time measurements by the firmware that was checked for proper operation during the Built-In-Test. The design of the firmware was verified as part of the certification process.

This test requires the SpeedLaser to measure the time it takes a light pulse to travel from the SpeedLaser to a target and back. Since the speed of light in air is known, the SpeedLaser can calculate the range to the target. The operator then compares the reported range to the known distance the light pulse traveled. To verify that the timing hardware is working correctly the computed range must match the known distance to within a known tolerance. At least two such comparisons must be made.

In normal operation the SpeedLaser measures the time it takes for a light pulse to travel from the SpeedLaser to a moving vehicle and back. The SpeedLaser makes hundreds of such round trip time measurements each second, each time measurement is converted to a range and stored. When the SpeedLaser has sufficient stored ranges, it performs a linear regression calculation that yields the speed of the vehicle. Numerous firmware filters are used to confirm the computed speed before it is displayed.

**ALIGNMENT TESTS (Horizontal):**

This is a test to confirm that the sighting system and the invisible light pulse emitted by the SpeedLaser are aligned horizontally. The operator uses the sighting system to aim at an object and then confirms that the light pulses of the SpeedLaser are hitting that object by observing that the SpeedLaser is reporting the range to that object. The operator then moves the sighting system off of the object and observes that the reported range changes just as the sighting system is no longer on the object.

**ALIGNMENT TEST (Vertical):**

Same as Horizontal alignment test but in the vertical axis.

## APPENDIX A

### TROUBLESHOOTING PROCEDURES

If you suspect your SpeedLaser is malfunctioning, please check the following items:

#### Troubleshooting

Symptom	Possible Cause
SpeedLaser won't power on	Battery not charged sufficiently; 12 V adapter not plugged in
SpeedLaser won't range to extremely distant targets	Target not reflective enough, target too far away, Lens Blocked or fogged
Cannot see HUD displays	HUD Brightness set too low

#### Error Messages

Error Message	Message Meaning	Operator Action
EEPROM Data Not Found	SpeedLaser setup defaults not located	Cycle Power
HELP	Voltage too low	Recharge the Battery Handle
Low Battery	Voltage too low	Recharge the Battery Handle

If you are unable to resolve the problem on your own, please contact Laser Atlanta Technical Support by any of the following methods:

voice: (770) 446-3866 fax: (770) 840-0462  
 email: [techsupport@LaserAtlanta.com](mailto:techsupport@LaserAtlanta.com)  
<http://www.LaserAtlanta.com>

If you need to return your unit for service, please call first to receive a Return Materials Authorization (RMA) number.

# **APPENDIX B**

## **CARE AND MAINTENANCE**

### **General Care Considerations**

#### **DO**

- Transport the SpeedLaser in its carrying case
- Occasionally clean the SpeedLaser Optics (see procedure below)

#### **DO NOT**

- Operate while the battery charges
- Point the SpeedLaser at the sun
- Place on unstable surfaces
- Open the SpeedLaser

### **CLEANING THE SPEEDLASER'S OPTICS**

---

**WARNING!** The SpeedLasers optical surfaces are coated glass. Care must be taken when cleaning these surfaces. Scratching the lenses may lead to reduced performance.

#### **Surfaces to Clean**

The LASER TRANSMITTER OPTICS, RECEIVER OPTICS, HUD COMBINER GLASS, and HUD SEALING WINDOW may be cleaned as needed.

#### **Materials**

1. Lint-free cloth or optical cleaning tissue
2. Soft bristled brush
3. Isopropyl Alcohol

#### **Method**

1. Brush loose debris from optical surfaces with brush or cloth.
2. Moisten cloth with isopropyl alcohol.
3. Gently wipe optical surface in a circular motion. Change tissue if any debris is visible.

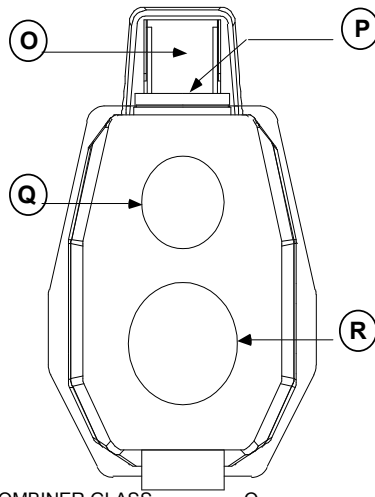

O. HUD COMBINER GLASS  
P. HUD SEALING WINDOW  
Q. TRANSMITTER OPTICS  
R. RECEIVER OPTICS

O. H  
P. H



## APPENDIX C

### TECHNICAL SPECIFICATIONS

<b>Dimensions</b>	25.4 cm x 8.4 cm x 28 cm
<b>Weight</b>	2.09 kg including battery
<b>Laser</b>	Classification: Class I (21 CFR 1040.10&1040.11) Wavelength: 904 nm Beam Divergence: 3 mrad x 3 mrad Acquisition Time: 0.3 seconds
<b>Speed</b>	Range Max: 9144 m
<b>Measurement</b>	Accuracy: $\pm 1$ kph Acquisition: 0.3 sec Limits Approaching: +16 to +322 kph Limits Receding: -16 to -322 kph
<b>Distance Range:</b>	2 - 9 144m
<b>Measurement Accuracy:</b>	$\pm 31$ cm
<b>Data I/O Type:</b>	RS-232 Serial Data
<b>Internal Recording:</b>	PCMCIA Type II SRAM
<b>Power/ Batteries</b>	Nom. Voltage Range: 5.7 to 6.7 VDC Battery Type: NiMh Firing Current: 400 mA (backlight off) Standby Current: 200 mA (backlight off) Low Voltage Alert: 5.7 VDC
<b>Charger/ 12 V Adapter</b>	Voltage Range: 10.8 to 13.6 VDC
<b>Displays</b>	Rear Panel: 4 line x 20 char. LCD Head Up Display: 1 line x 4 char. LED and aiming crosshair
<b>Temperature</b>	Storage: -30° C to 60° C Operating: -40° C to 80° C (90% R.H. non-condensing)
<b>Enclosure:</b>	Water Resistant

# Appendix D

## *SpeedLaser & Accessories*

Standard Package

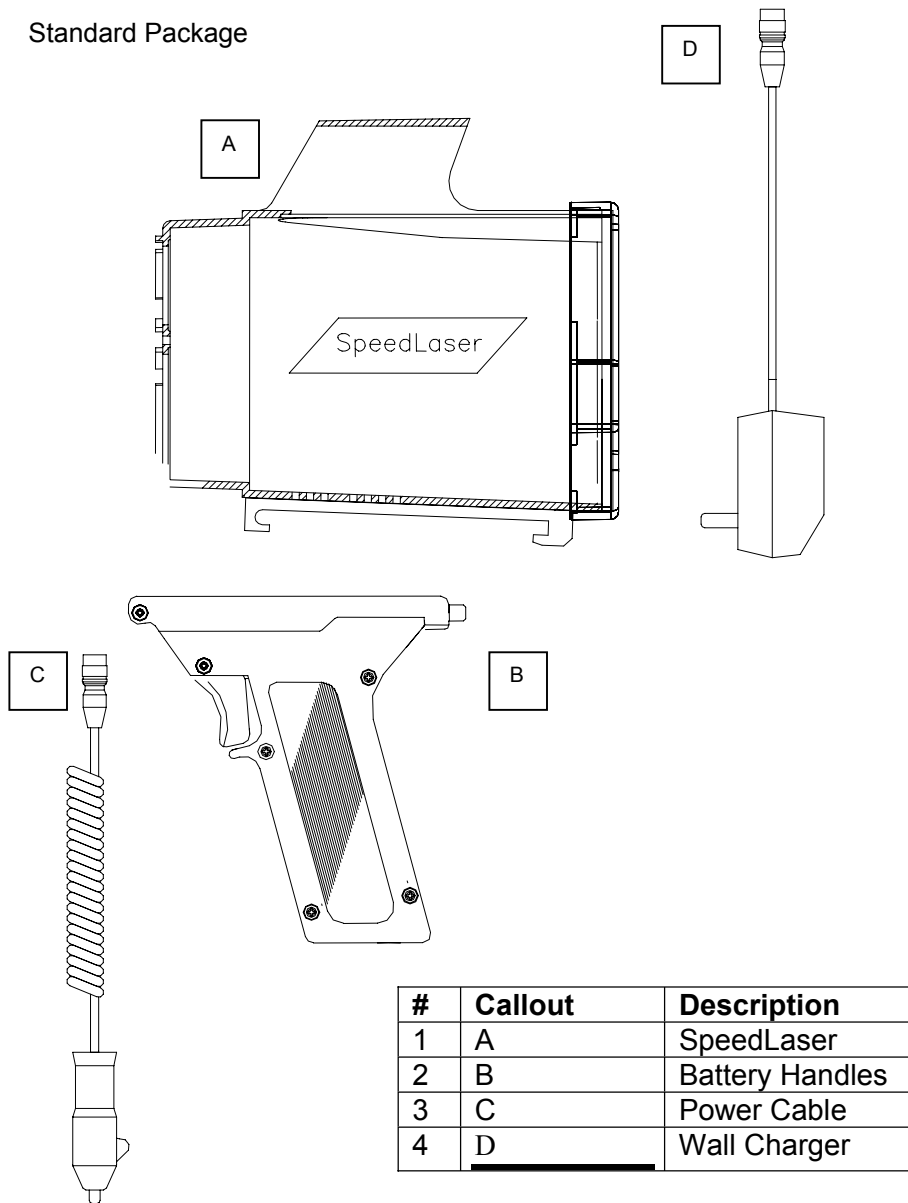

#	Callout	Description
1	A	SpeedLaser
2	B	Battery Handles
3	C	Power Cable
4	D	Wall Charger

# Appendix E

## *Measuring Surface Datum*

The measuring surface datum is located 10.8 centimeters back from the face of the gun. (This location corresponds to the vertical center of gravity of the unit.)

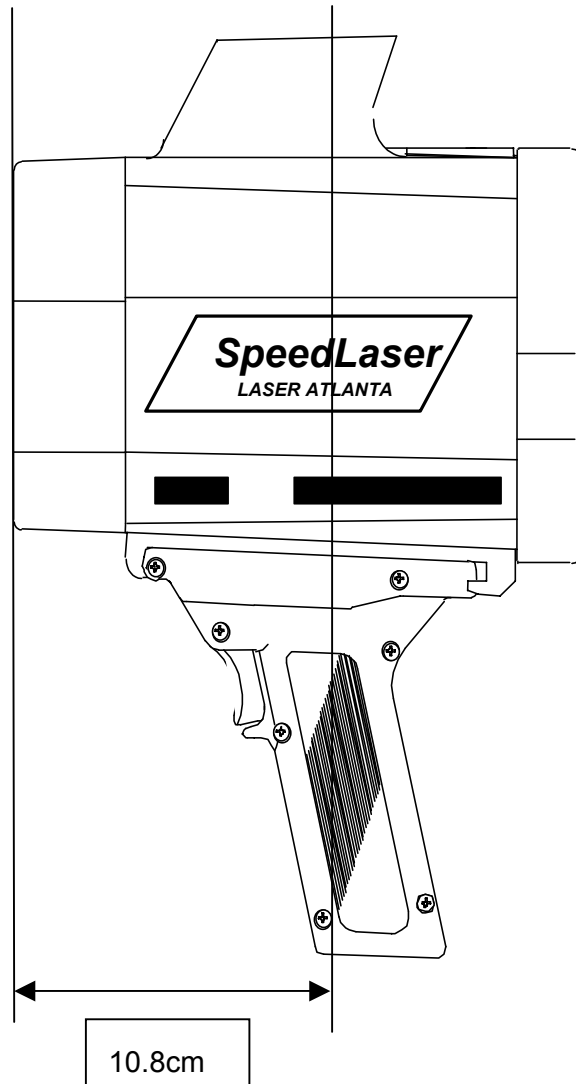

# Appendix F

## *Battery Handles Notes*

The battery voltage reading is accessed from the SELF-TEST function of the unit. See page 20 for more information.

### **Voltage Reading When Fully Charged**

Immediately after charging the NiMh battery handle, the voltage may temporarily read 7.0 volts or higher. It will quickly taper down to approximately 6.5 volts. This is a normal characteristic of NiMh battery cells.

### **Voltage Reading While Operating**

Nominal battery voltage is 6.0 to 6.5 volts. This voltage range will appear while you are using an adequately charged handle.

### **Voltage Reading When Battery is Near Empty**

After approximately 4 to 5 hours of typical use, the battery voltage will start to drop below 6.0 volts. When the voltage reaches 5.8 volts, the unit will emit a warning buzzer tone and the unit will no longer operate. At this point the handle must either be recharged, or you may switch to a 12V supply or another handle.

### **Operating With a Discharged Handle and a 12V Source**

The unit can be operated from a 'dead battery' (discharged handle) with the use of the 12V wall power adapter or 12V cigarette adapter. To do this you should follow the procedure below:

- 1) Charge the handle for 5 or more minutes from the 12 V source.
- 2) Leave the 12V source attached to the handle and attach the handle to the SpeedLaser unit (if not already attached.)
- 3) Turn the unit on.
- 4) Note the voltage displayed (by the self-test function.)
- 5) If the display reads 6.0 volts or higher, begin using the unit. If it display <6.0 volts, repeat step 1).

The unit should now operate normally as long as the 12V supply is hooked up.

## **Limited Warranty**

Laser Atlanta warrants all SpeedLaser® products to be free from defects in materials and workmanship for a period of one (1) year from date of purchase. This warranty specifically excludes batteries and software. During this warranty period Laser Atlanta will replace defective materials and correct faulty workmanship at no charge, provided the product is returned to Laser Atlanta within the warranty period. If Laser Atlanta is unable to replace defective materials or correct faulty workmanship, Laser Atlanta will replace the product at no charge. These are your sole remedies for any breach of warranty.

## **Return Policy**

It is Laser Atlanta's policy and objective to allow prospective purchaser's ample opportunity to become familiar with our products prior to purchase. We do so through our product rental and demonstration programs. Customer satisfaction is very important to Laser Atlanta and we make every attempt to please customers whenever possible.

We are committed to designing and manufacturing products to the highest standards of quality and reliability. We offer an extended warranty that covers all materials and workmanship. In spite of our best efforts we do not want customers to incur unreasonable inconvenience due to equipment failure. Laser Atlanta will replace any product, or make a full refund, if repairs cannot be made to the satisfaction of the customer within the initial sixty days of ownership. After the initial sixty days of ownership Laser Atlanta will honor its warranty through either the repair or replacement of any malfunctioning products.



**LASER ATLANTA OPTICS, INC.**

2827 PETERSON PLACE  
NORCROSS, GA 30071

TEL: 770-446-3866  
FAX: 770-840-0462

E-MAIL: SALES@LASERATLANTA.COM

HTTP://WWW.LASERATLANTA.COM

P/N 40150-E1CN  
(FOR 4.X)