



# Asphalt Shingle Roofing



This handout provides answers to frequently asked questions relating to when you need a new roof, recommendations for installation and building permits.

## General Details

Building permits are required for re-roofing existing dwellings. Building permit fees and required inspections can be obtained by contacting your local department of building safety. Building inspections are performed at various stages to verify code compliance.

The 2020 Minnesota Residential Code adopts the 2018 International Residential Code (IRC). Roofing materials must be installed in accordance with Chapter 9 of the 2020 Minnesota Residential Code and the manufacturer's installation instructions (R905.1).

The Minnesota State Building Code is the standard of construction for the entire state (Minnesota Statute 326B.121). The 2020 Minnesota Residential Code can be viewed at <https://codes.iccsafe.org/content/document/1581>.

**All roofing must be installed per manufacturer's requirements.**

## Easement Vacation Application

If there are existing easements, these will have to be vacated ( aka "removed") from the property while new easements will be dedicated on the final plat. The vacation application is processed simultaneously with the subdivision application.

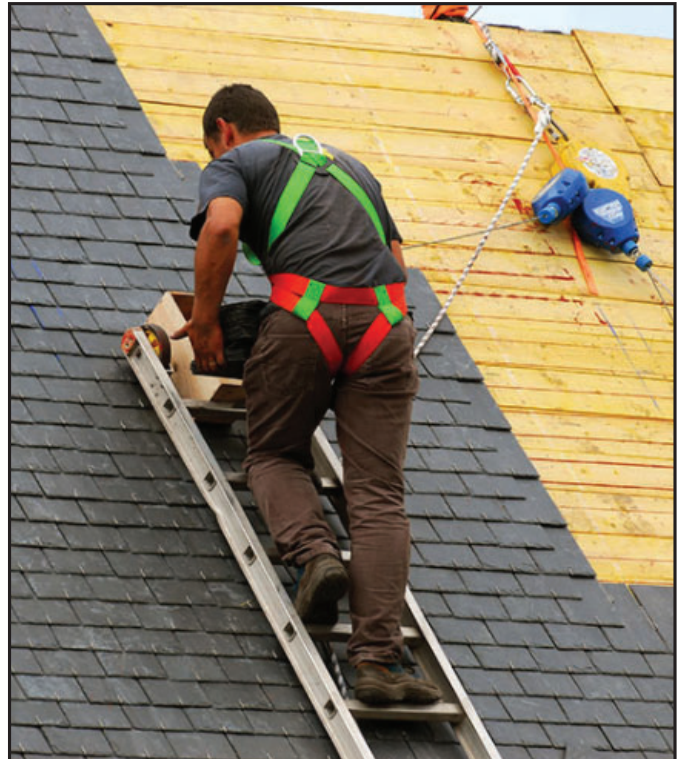

## RECOVERING vs. REPLACEMENT

- Do not install new roof coverings without first removing all existing layers of roof coverings where any of the following conditions exist:
- Where the existing roof or roof covering is water-soaked or has deteriorated to the point that the existing roof or roof covering is not adequate as a base for additional roofing.
- Where the existing roof covering is wood shake, slate, clay, cement or asbestos-cement tile.
- Where the existing roof has two or more applications of any type of roof covering.

## Exceptions

1. Complete and separate roofing systems, such as standing-seam metal roof systems that transmit the roof loads directly to the building's structural system do not require the removal of existing roof coverings.
2. Installation of metal panel, metal shingle and concrete and clay tile roof coverings over existing wood shake roofs are not permitted when the application is in accordance with Section R908.4.
3. The application of new protective coating over existing spray polyurethane foam roofing systems is permitted without tear-off of existing roof coverings.
4. Where the existing roof assembly includes an ice barrier membrane that is adhered to the roof deck, the existing ice barrier membrane is permitted to remain in place and be covered with an additional layer of ice barrier membrane in accordance with Section R905 and the manufacturer's installation instructions.

## Frequently Asked Questions

Before undertaking any re-roofing project, there are several questions to consider to ensure a successful project. Familiarize yourself with all aspects of the re-roofing process.

**Do I need a new roof?** How old is it? A roof that has been properly installed, ventilated, and has not been damaged can last 20 years or more. An inspection of the roof should be done periodically. Look for cracks, curled or cupped shingles, worn mineral coatings, exposed nails, previous patches, holes and exposed underlayment or sheathing.

**Does the roof leak?** If the answer is yes, it is necessary to determine why. If you have inspected the roof and it looks sound, the problem could be roof flashing. Many roof leaks are result of bad or misapplied flashing. You should spend time in the attic looking for water stains, particularly around vents, chimneys and vertical wall elements above the roof. Flashing can sometimes be replaced or repaired without installing a whole new roof.

**Do it myself or hire a professional?** This is a question only you can answer based on your skill level and time. An asphalt roofing project can be successfully accomplished by the homeowner if you take the time to become familiar with the roofing procedures. Be sure to plan your project around the weather and allow enough time to get a proper cover on the roof before it rains. Steep-sloped asphalt roofs and those with multiple valleys can present special problems, so be sure you have the right equipment and skills before undertaking this type of roofing project.

Other types of roofs such as wood shingles, shakes and clay tile normally require special skills for installation. If you decide to hire a professional, be sure the company is a state-licensed contractor or roofer.

**Should I overlay the existing roof or tear off the existing shingles?** There are two options available for re-roofing installations. One would be to tear off the old roof before applying the new one. The second would be to lay new shingles over the existing roof. Roofing materials are heavy, so multiple layers can affect the ability of a roof to hold the weight of winter snow.

An overlay can be the less expensive option; however, it is not necessarily always the best choice. There are advantages to tearing off the old roof before installing a new one.

For example:

- If there are any defects in the roof deck, they will be revealed when the roof is torn off. These defects should be repaired before applying the new roof. If condensation problems exist in the attic, they too will be revealed when the roof is torn off. Properly designed attic ventilation can then be installed in order to help eliminate such problems.
- When the old roof is torn off, an ice-protection underlayment must be installed before applying the new roof. This will help prevent ice damage.



- Tearing off the old roof and starting with a clean deck before re-roofing may result in a smoother finished-roof system.
- Tearing off the old roof will typically result in a longer roof life than when the roof has been laid over. This is because they are installed smooth over sound material and have new underlayment installed.

An overlay of asphalt shingles must also comply with the shingle manufacturer's installation instructions for overlays.

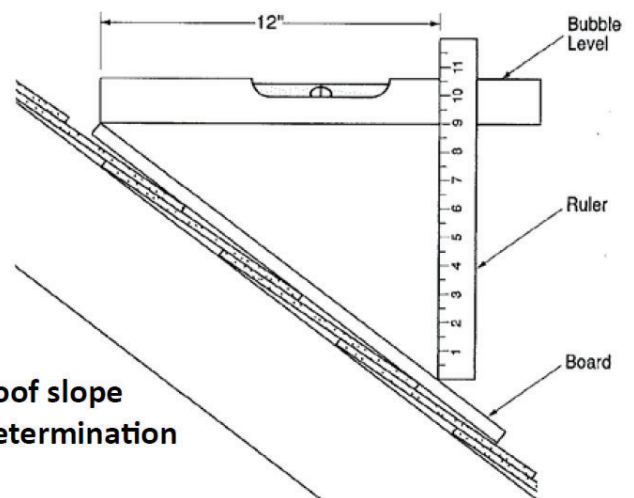

### What is roof slope and does it limit the choice of shingles?

Asphalt shingles can only be used on roof slopes of two units vertical in 12 units horizontal (2:12) or greater.

The slope of the roof is measured by the vertical rise of the roof to the horizontal run and is expressed as a fraction. A "4:12 roof slope" means the roof rises 4 ft. for every 12 ft. of horizontal roof span. Roof slopes between 2:12 and 4:12 can use shingles, but require roof application techniques to take into account a greater potential for ice dam water backup. Roof slopes between 2:12 and 4:12 require a double underlayment application in accordance with Section R905.2.7. Slopes of 4:12 and above can use standard asphalt roofing applications (R905.2.2).

### What are the ventilation requirements?

Roof ventilation is required and must be installed in accordance with Section R806 of the 2020 Minnesota Residential Code and the manufacturer's installation instructions.

Enclosed attics and enclosed rafter spaces formed where ceilings are applied directly to the underside of the roof rafters must have cross ventilation for each separate space by ventilating openings protected against the entrance of rain or snow. Ventilating openings must be provided with corrosion-resistant wire cloth screening, hardware cloth mesh, or similar material with 1/16-inch minimum to 1/4-inch maximum openings.

**Minimum vent area:** The minimum net free ventilating area is 1/150 of the area of the vented space.

The minimum net free ventilation area is 1/300 of the vented space provided both of the following conditions are met:

1. A Class I or II vapor retarder is installed on the warm-in winter side of the ceiling.
2. At least 40 percent and not more than 50 percent of the required ventilating area is provided by ventilators located in the upper portion of the attic or rafter space. Upper ventilators can be located no more than 3 ft. below the ridge or highest point of the space, measured vertically. The balance of the required ventilation must be located in the bottom one-third of the attic space. Where the location of wall or roof framing members conflict with the installation of upper ventilators, installation more than 3 ft. below the ridge or highest point of the space are not permitted.

It might be necessary to add ventilation with your new roof to meet these standards.

## Code Requirements for Asphalt Shingles

We've looked at the typical installation of asphalt shingles for use on roofs 4:12 and greater; however, the code also permits application on a roof that has a slope of less than 4:12 if the low-slope-roofing procedures are used.

### Roof deck sheathing

Roof covering materials such as asphalt shingles must be installed on solidly sheathed roofs. Solidly sheathed roofs include structural panels such as plywood and oriented strand board (OSB) with 1/8" gaps between panels as required by panel manufacturers.

Wood boards are also considered as solidly sheathed, provided the spacing between boards complies with the shingle manufacturer's installation requirements. If the spacing between boards is too large, a structural panel applied over the deck boards is required to be considered a solidly sheathed roof.

### What function does shingle underlayment serve?

An underlayment, commonly known as roofing felt, will:

- Protect the roof deck from moisture prior to shingle application.
- Provide a degree of back-up protection in the event water gets under roofing shingles.

Protection against ice dams can be obtained by using a special waterproof shingle underlayment at the eaves or lower edges of the roof, in addition to installing adequate ventilation and proper insulation in the attic. The code in Minnesota requires this special waterproof shingle underlayment at the eaves or lower edges of the roof.

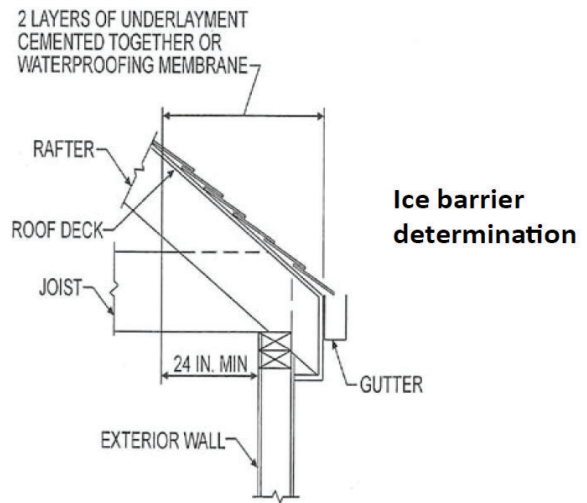

### How can you determine if the roof is properly ventilated?

An attic needs to breathe. An effective ventilation system will help prevent attic heat build-up, attic moisture and condensation, and ice dam build-up.

Research has shown that proper ventilation is necessary if the shingles are to last their design life.

### Fasteners

Fasteners must be galvanized steel, stainless steel, aluminum or copper roofing nails, minimum 12-gage shank with a minimum 3/8 inch head, of a length to penetrate through the roofing materials and a minimum of 3/4 inch into the roof sheathing. Where the roof sheathing is less than 3/4 inch thick, the fasteners must penetrate through the sheathing. Fasteners must comply with ASTM F 1667. Staples are not permitted for shingle application unless specifically noted in the manufacturer's installation instructions on the shingle package.

### Underlayment

The code requires underlayment of one layer of nonperforated Type 15 felt lapped two inches horizontally and four inches vertically, to shed water. In addition, an ice barrier that consists of at least two layers of underlayment cemented together or of a self-adhering polymer modified bitumen sheet, be used in lieu of normal underlayment

and extend from the eave's edge to a point at least 24 inches inside the exterior wall line of the building. Ice barrier protection at eaves is required in Minnesota.

### **Valley linings**

Install valley linings in accordance with manufacturer's installation instructions before applying shingles.

Permitted valley linings include:

1. For open valley (valley lining exposed) lined with metal: 24 inches wide and of any of the corrosion-resistant metals in Table R905.2.8.2.
2. For open valleys: Two plies of mineral surface roll roofing, complying with ASTM D 3909 or ASTM D 6380 Class M. The bottom must be 18 inches and the top layer a minimum of 36 inches wide.
3. For closed valleys (valley covered with shingles): one ply of smooth roll roofing complying with ASTM D 6380 and at least 36 inches wide or valley lining as described in items 1 and 2. Self-adhering polymer modified bitumen underlayment complying with ASTM D 1970 can be used in lieu of the lining material.

### **Cricket and saddle**

Install a cricket or saddle on the ridge side of any chimney greater than 30 inches wide.

Cricket or saddle coverings must be sheet metal or the same material as the roof covering.

### **Sidewall flashing**

Sidewall flashing against a vertical sidewall must be continuous or step flashing and a minimum of 4 inches in width and direct water away from the vertical sidewall onto the roof or gutter.

### **Kickout flashing**

Install kickout flashing where the lower portion of a sloped roof stops within the plane of an intersecting wall cladding to divert or kick out water away from the assembly.

### **Other flashing**

Apply other flashing, such as flashing against a vertical front wall and the soil stack, vent pipe and chimney flashing, according to the asphalt shingle manufacturer's instructions. Replace existing flashings that are part of the assembly where rusted, damaged or deteriorated.

Flashing must be reconstructed to comply with approved manufacturer's installation instructions.

### **Drip edge**

Drip edge is not required unless specifically required by the manufacturer's installation instructions.

### **Repairs or replacement of asphalt shingles**

Repair or replacement of asphalt shingles damaged by wind or other events are not addressed in the 2020 Minnesota Residential Code. Repair or replacement of asphalt shingles is only permitted when complying with the shingle manufacturer's specified installation instructions for such work.

### **Wind speed design for asphalt shingles**

The 2020 Minnesota Residential Code requires shingles to be designed for a 115 mph maximum ultimate design wind speed (R301.2.1). This wind speed equates to a maximum basic wind speed of 90 mph, the same as required in previous codes. Asphalt shingle product labeling must indicate compliance with ASTM D3161 classifications A, D, F or ASTM D7158 classifications D, G, H and identify a maximum ultimate design wind speed of at least 115 mph (R905.2.4.1).